



(12) **EUROPEAN PATENT APPLICATION**

(43) Date of publication:  
**01.10.2003 Bulletin 2003/40**

(51) Int Cl.7: **F16B 31/02**

(21) Application number: **03251957.1**

(22) Date of filing: **27.03.2003**

(84) Designated Contracting States:  
**AT BE BG CH CY CZ DE DK EE ES FI FR GB GR**  
**HU IE IT LI LU MC NL PT RO SE SI SK TR**  
 Designated Extension States:  
**AL LT LV MK**

(72) Inventor: **Junkers, John K.**  
**Saddle River, New Jersey 07458 (US)**

(74) Representative: **Hanson, William Bennett**  
**J.Y. & G.W. Johnson,**  
**Kingsbourne House,**  
**229-231 High Holborn**  
**London WC1V 7DP (GB)**

(30) Priority: **29.03.2002 US 112101**

(71) Applicant: **Junkers, John K.**  
**Saddle River, New Jersey 07458 (US)**

(54) **Washer, fastener provided with a washer, method of and power tool for fastening objects**

(57) A washer (1) has a body (2, 2') having a first bearing face surface (3) at one axial side and adapted to cooperate with a nut (10), a second bearing face surface (4) at an opposite axial side and adapted to cooperate with an object (18), at least one third turning resistant surface (5) adapted to cooperate with a thread (13) of a bolt (12), and at least one breaking point arranged so that when the nut (10) is turned and turns the

bolt (12) the washer (1) stops the bolt from turning and thereby the nut (10) creates a pull on the bolt (12) which elongates the bolt in an axial direction and applies to the washer an axial force which breaks said body (2, 2') of the washer (1) and allows a portion of said body of the washer to be pulled axially when the bolt (12) elongates; and also a fastener, a method of fastening objects, and a tool (15) for fastening objects can be provided with the new washer.

*FIG. 1*

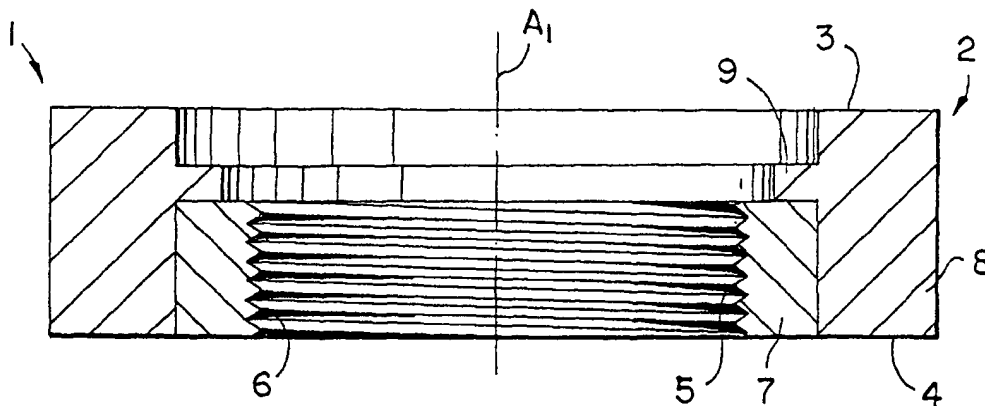

**EP 1 348 878 A1**

## Description

[0001] The present invention relates to a washer, a fastener provided with a washer, and a method of and a power tool for fastening objects.

[0002] It is known to fasten objects with one another with power tools which use fasteners having a multi-part replacement nut, for example including an inner sleeve, an outer sleeve, and a washer. Such a replacement nut is disclosed for example in US-A-5,341,560. Another replacement nut is disclosed in US-A-6,254,323 in which a bolt has a spline underneath its upper thread, to which a washer is non-rotatably connected, and the bolt also has engaging means for applying a reaction force, while an active force of the same tool turns the nut on the bolt thread and the washer face. In the fastener disclosed in both above mentioned patents, the common features are the use of the action and reaction force of one tool, the elimination of reaction arms on power tools, the conversion of torque to torsion-free bolt stretching and obtaining for the first time the desired residual bolt load rather than a torque which is estimated based on calculated frictions rather than on actual frictions or a tension, which is based on estimated bolt relaxation when the force is transmitted from the elongated bolt to the hand-tight nut.

[0003] One solution is disclosed in my US patent application serial no. 10/010,377. In this patent application a washer is proposed which has a first bearing face surface located at one axial side and cooperating with a nut, a second bearing surface located at an opposite axial side and cooperating with an object, and at least one third turning resistant surface cooperating with a thread of the bolt so that when the nut is turned with a given force in one direction and a body of the washer receives a given force in an opposite direction, only the nut turns to tighten or loosen the bolt and the body of the washer remains rotation stationary, while the bolt elongates or relaxes in an axial direction. However, it can be made more manufacturing friendly to reduce its manufacturing cost.

[0004] Accordingly, it is an aim of the present invention to provide a washer, a fastener provided with a washer, a method of and a power tool for fastening with the use of the washer, which provides a further solution to the above specified problems.

[0005] In keeping with these aims and with others which will become apparent hereinafter, one aspect of the present invention resides in a washer according to claim 1. Another aspect of the present invention resides in a fastener according to claim 4. Still another aspect of the present invention resides in a method of assembly at least two parts of an object according to claim 7. In accordance with still a further aspect of the present invention, a power tool for fastening an object according to claim 8 is proposed.

[0006] In accordance with one embodiment of the present invention, the washer body can be composed

of two part arranged so that one part prevents initially an axial displacement of the other part which is engaged with the bolt, and thereafter one of said parts is broken under the action of the axial force applied in response to the elongation of the bolt.

[0007] In accordance with another feature of the present invention, the washer body can be formed as a one-piece integral element, which subsequently is broken at the breaking point when the axial force is applied by the elongating bolt to the washer.

[0008] The present invention will be best understood from the following description of specific embodiments, given by way of example only, when read in connection with the accompanying drawings, in which:

Figure 1 is a view showing a washer in accordance with the present invention;

Figure 2 is a view showing a fastener with a washer and a tool applied to the fastener, and illustrating a fastening method in accordance with the present invention; and

Figure 3 is a view showing a further embodiment of the washer in accordance with the present invention.

[0009] Figure 1 shows a washer in accordance with the present invention, which is identified with reference numeral 1 as a whole. The washer 1 has a body, which is identified with reference numeral 2. The body 2 of the washer 1 has a first upper bearing face surface 3 adapted to cooperate with a nut, a second lower bearing race surface 4 adapted to cooperate with an object which can be formed as two parts to be assembled with one another, and at least one turning resistant surface identified with reference numeral 5.

[0010] The first and second bearing face surfaces 3 and 4 are spaced from one another in an axial direction or in other words in a direction of an axis  $A_1$ . The at least one third turning resistant surface 5 is located radially inwardly of the body 2 of the washer 1. The third turning resistant surface 5 is formed so as to engage with or wedge in a thread of the bolt, for example by providing a corresponding thread 6 on the turning resistant surface 5.

[0011] As can be seen from Figure 1, the body 2 of the washer 1 is composed of two parts 7 and 8 located substantially radially adjacent to one another, so that the part 7 is located radially inwardly of the part 8. The turning resistant surface 5 with the thread 6 is provided radially inwardly on the part 7. The part 8 has a projection 9, which is located above the part 7 and prevents axial upward displacement of the part 7. However, the projection 9 is designed so that it can break under the action of a certain force acting in an axial upward direction. The part 7 can be press fit, knurled, splined or otherwise connected with the part 8 in a manner resistant to turning.

- said body of the washer (1) and allows said portion of said body (2, 2') of the washer to be pulled axially when the bolt (12) elongates.
2. A washer (1) as defined in claim 1, wherein said body (2) has two parts (7, 8) arranged so that one part (8) prevents initially an axial displacement of the other part (7) which is engaged with the bolt (12), and thereafter said one (8) of said parts is broken under the action of the axial force.
  3. A washer (1) as defined in claim 1, wherein said body (2') is formed as a one-piece integral element, which subsequently is broken at a breaking point (31) under the action of the axial force.
  4. A fastener for connecting two parts (19/19') which constitute an object (18), comprising a bolt (12) having a thread (13); a nut (10) screwable on said bolt (12); and a washer (1) to be applied between the nut (10) and the object (18) and including a body (2, 2') having an axis and provided with a first bearing face surface (3) located at one axial side and adapted to cooperate with the nut (10), a second bearing face surface (4) located at an opposite axial side and adapted to cooperate with the object (18), and at least one third turning resistant surface (5) adapted to cooperate with the thread (13) of said bolt (12), said body (2, 2') of said washer (1) having at least one breaking point arranged so that when the nut (10) is turned and turns the bolt (12) said body (2, 2') of the washer stops the bolt from turning and thereby the nut (10) creates a pull on the bolt (12) which elongates the bolt in an axial direction and applies to said body (2, 2') of the washer (1) an axial force which breaks a portion (9, 31) of said body of the washer and allows said portion of said body (2, 2') of the washer (1) to be pulled axially when the bolt (12) elongates.
  5. A fastener as defined in claim 4, wherein said body (2) has two parts (7, 8) arranged so that one part (8) prevents initially an axial displacement of the other part (7) which is engaged with the bolt (12), and thereafter said one (8) of said parts is broken under the action of the axial force.
  6. A fastener as defined in claim 4, wherein said body (2') is formed as a one-piece integral element, which subsequently is broken at a breaking point (31) under the action of the axial force.
  7. A method of assembly of at least two parts (19, 19') of an object (18) with one another, comprising the steps of introducing a bolt (12) having a thread (13) into the parts (19, 19') so that a free end of the bolt extends outwardly beyond at least one side of the parts; placing a washer (1) on the free end of the bolt (12); threadingly connecting a nut (10) to the free end of the bolt so as to abut against the washer (1); placing a power tool (15) so as to turn the nut (10) with a rotatable element (16) of the power tool connected to the nut to tighten or loosen the bolt (12) and applying a non-rotatable element (17) of the power tool (15) to the washer (1) to absorb a reaction force; and providing the body (2, 2') of the washer with a breaking point arranged so that when the nut (10) is turned and turns the bolt (12) said body (2, 2') of the washer (1) stops the bolt from turning and thereby the nut (10) creates a pull on the bolt (12) which elongates the bolt in an axial direction and applies to said body of the washer an axial force which breaks a portion (9, 31) of said body (2, 2') of the washer (1) and allows said portion of said body of the washer to be pulled axially when the bolt (12) elongates.
  8. A power tool (15) for fastening an object (18), comprising a housing (20) provided with a non-rotatable element (17); a power drive (21) in said housing driving a rotatable driving element (16); a fastener part including a bolt (12) having a thread (13) and an axis (A<sub>2</sub>) and introducible into parts (19, 19') forming the object (18), a nut (10) screwable on said bolt (12) and cooperating with said driving element (16), and a washer (1) to be applied between said nut (10) and the object (18) and cooperating with said non-rotatable element (17) of said housing, said washer (1) having an axis (A<sub>1</sub>) and being provided with a first bearing face surface (3) located at one axial side and adapted to cooperate with said nut (10), a second bearing face surface (4) located at an opposite axial side and adapted to cooperate with the object (18), and at least one turning resistant surface (5) adapted to cooperate with said thread (13) of said bolt (12), so that when said nut (10) is turned by said driving element (16) and turns said bolt, the body (2, 2') of said washer (1) is held by said non-rotatable element (17) and stops said bolt (12) from turning and thereby said nut (10) creates a pull on said bolt which elongates said bolt (12) in an axial direction and applies to said body (2, 2') of said washer (1) an axial force which breaks a portion (9, 31) of said body of said washer and allows said portion of said body (2, 2') of said washer (1) to be pulled axially when said bolt (12) elongates.

**[0012]** Figure 2 shows a fastener provided with the washer, with a tool applied to the fastener. The fastener has a nut 10 having an inner thread 11. The fastener further has a bolt 12 provided with an outer thread 13, and having an axis  $A_2$ . The nut 10 has a lower bearing face surface 14 which is adapted to be placed on the upper bearing face surface 3 of the body 2 of the washer 1. The outer thread 13 of the bolt 12 engages with the inner thread 11 of the nut 10, and also engages with an inner thread 6 of the body 2 of the washer 1.

**[0013]** A power tool in accordance with the present invention is shown in Figure 2 and identified with reference numeral 15. The power tool has a housing, which is identified with reference numeral 20 and a power drive, which is identified with reference numeral 21. The power drive is formed for example as a cylinder-piston unit which includes a cylinder 24 and a piston 25 which is movable in the cylinder and provided with a piston rod 26. The reciprocating movement of the piston rod 26 with the piston 25 is converted into a rotary movement of a ratchet 28 through at least one drive plate 27 provided with a not shown pawl engageable with teeth of the ratchet 28. A driving element 16 is connected with the turnable ratchet 28 on the one hand and engages the nut 10 on the other hand. In order to provide such an engagement the inner surface of the driving element 16 can be provided with connecting means, for example formed as a polygonal inner surface, etc. A non-rotatable element 17 is connected to the immovable housing 20 to absorb a reaction created during turning of the driving element. The non-rotatable element 17 engages the body 2 of the washer 1 to prevent its rotation about the axes  $A_1$  and  $A_2$ , which coincide with one another when the fastener is assembled. In order to engage the washer, the non-rotatable element 17 is provided with connecting means formed for example as a polygonal inner surface, etc.

**[0014]** The fastener with the washer is provided for fastening an object which is identified with reference numeral 18, in particular, to assemble parts 19 and 19' of the object 18 with one another.

**[0015]** When, as shown in Figure 2, the power tool 15 is placed on the fastener so as to tighten or loosen the nut, the turning element 16 which is connected to the nut 10 turns the nut to overcome a thread friction with the bolt 12 and the facial friction with the washer 1 so as to turn the nut, and the non-rotatable element 17 holds the washer 1 to absorb the reaction force due to the facial friction of the washer 1 with the nut 10, its facial friction with one side of the part 19', and its turning friction with the bolt 12, so that the washer 1 does not turn but absorbs the reaction force of the power tool. Initially, when the nut 10 rotates, the bolt 12 rotates together with the nut; however, the stationary washer 1 wedges the stationary part 7 into the bolt thread 13, so that the bolt stops turning because of the interengagement of its outer thread 13 with the thread 6 of the washer 1. Therefore, the bolt 12 is stopped, and an axial force is applied to

the washer 1, in particular to its part 7 in an axial upward direction when the bolt 12 is elongated by the turning nut 10. Under the action of this axial upward force, the projection 9 of the part 8 of the washer 1 breaks off and the part 7 of the washer 1 is pulled upwardly.

**[0016]** Figure 3 shows another embodiment of the washer in accordance with the present invention. Here the washer which is identified with reference numeral 1' has a body 2' which is formed as a one piece integral element with a partition 31 and a groove 32 provided to reduce a thickness of the partition and to make it breakable.

**[0017]** The operation of the washer 1' in accordance with the second embodiment of the present invention is similar to the operation of the washer 1 of the embodiment shown in Figure 1. When the nut 10 is turned by the driving element 16 of the power tool, the bolt 12 has a tendency to turn together with the nut. As the washer 1 and consequently the inner part 7 are held stationary, the bolt becomes stationary due to the interengagement of its outer thread 13 with the inner thread 6' of the body 2' of the washer 1, but is elongated in the axial direction. An axial force which is generated during the elongation of the bolt 12 is applied axially upwardly to the radially inner part 7' of the washer 1', trying to displace the inner part 7', so that eventually it breaks the partition 31 and displaces the inner part 7' of the washer 1' axially upwardly relative to the outer part 8'.

**[0018]** It will be understood that each of the elements described above, or two or more together, may also find a useful application in other types of constructions differing from the types described above.

**[0019]** While the invention has been illustrated and described as embodied in washer, fastener provided with a washer, method of power tool for fastening with the use of the washer, it is not intended to be limited to the details shown, since modifications and structural changes may be made without departing in any way from the scope of the appended claims.

#### Claims

1. A washer (1, 1'), comprising a body (2, 2') having an axis ( $A_1$ ) and provided with a first bearing face surface (3) located at one axial side and adapted to cooperate with a nut (10), a second bearing face surface (4) located at an opposite axial side and adapted to cooperate with an object (18), at least one third turning resistant surface (5) adapted to cooperate with a thread (13) of a bolt (12), said body (2, 2') having at least one breaking point arranged so that when the nut (10) is turned and turns the bolt (12) said body (2, 2') of the washer (1) stops the bolt from turning and thereby the nut (10) creates a pull on the bolt (12) which elongates the bolt in an axial direction and applies to said body (2, 2') of the washer an axial force which breaks a portion (9, 31) of

FIG. 1

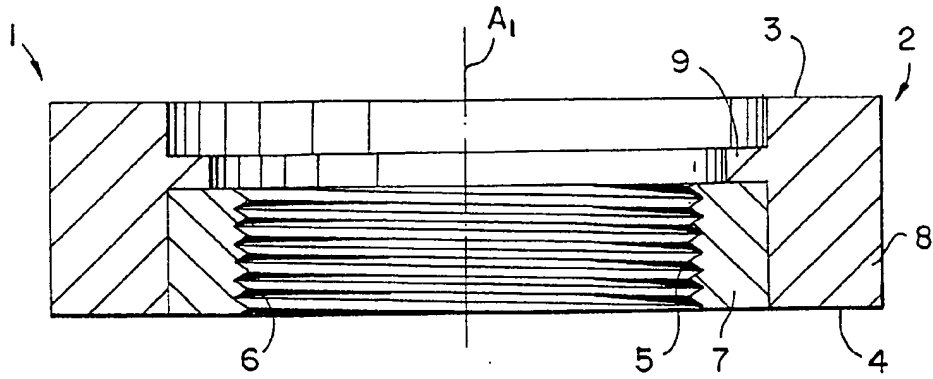
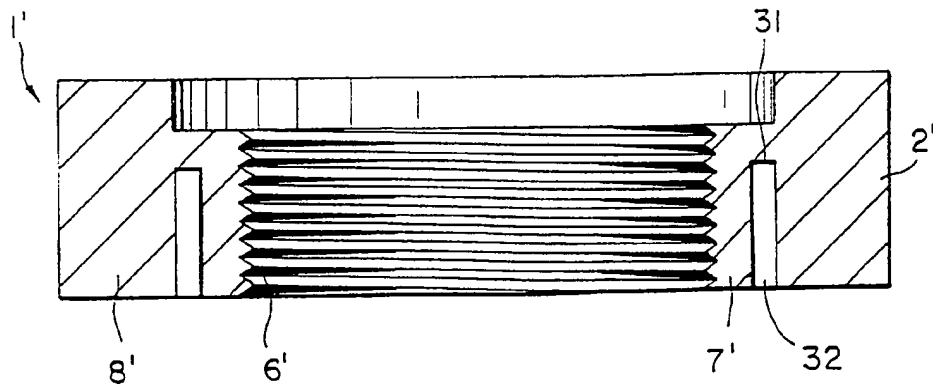

FIG. 3





European Patent Office

EUROPEAN SEARCH REPORT

Application Number  
EP 03 25 1957

DOCUMENTS CONSIDERED TO BE RELEVANT			
Category	Citation of document with indication, where appropriate, of relevant passages	Relevant to claim	CLASSIFICATION OF THE APPLICATION (Int.Cl.7)
A	DE 24 18 598 A (UPAT MAX LANGENSIEPEN KG) 30 October 1975 (1975-10-30) * page 7, line 3 - page 8, line 2; figure 3 *	1,7	F16B31/02
A	GB 1 330 320 A (MAC LEAN FOGG LOCK NUT CO) 19 September 1973 (1973-09-19)		
A	US 2001/039858 A1 (JUNKERS JOHN K) 15 November 2001 (2001-11-15) * the whole document *	8	
			TECHNICAL FIELDS SEARCHED (Int.Cl.7)
			F16B
The present search report has been drawn up for all claims			
Place of search MUNICH		Date of completion of the search 21 May 2003	Examiner Come1, E
CATEGORY OF CITED DOCUMENTS		T : theory or principle underlying the invention E : earlier patent document, but published on, or after the filing date O : document cited in the application L : document cited for other reasons & : member of the same patent family, corresponding document	
X : particularly relevant if taken alone Y : particularly relevant if combined with another document of the same category A : technological background O : non-written disclosure P : intermediate document			

EPO FORM 1503 03.82 (P04001)

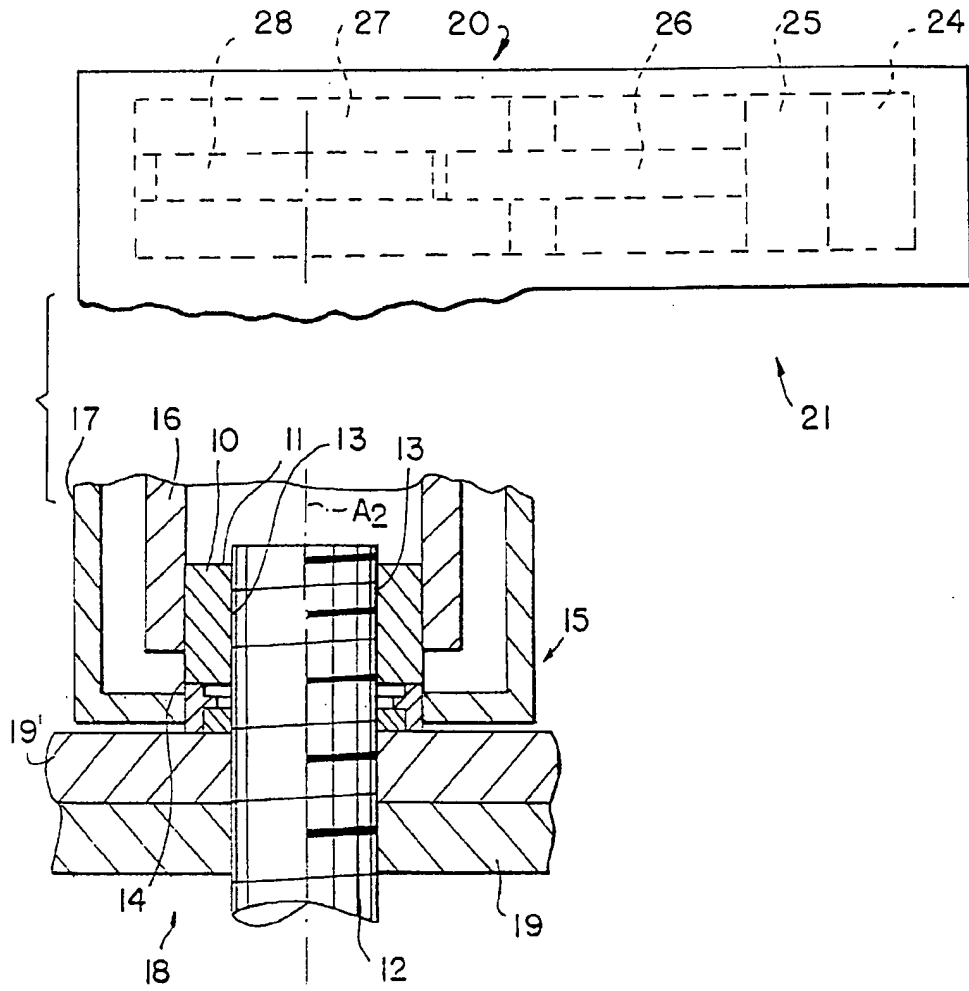

FIG. 2

**ANNEX TO THE EUROPEAN SEARCH REPORT  
ON EUROPEAN PATENT APPLICATION NO.**

EP 03 25 1957

This annex lists the patent family members relating to the patent documents cited in the above-mentioned European search report. The members are as contained in the European Patent Office EDP file on The European Patent Office is in no way liable for these particulars which are merely given for the purpose of information.

21-05-2003

Patent document cited in search report	Publication date	Patent family member(s)	Publication date
DE 2418598 A	30-10-1975	DE 2418598 A1	30-10-1975
GB 1330320 A	19-09-1973	AU 2095070 A	13-04-1972
US 2001039858 A1	15-11-2001	AU 739703 B2	18-10-2001
		AU 4883600 A	08-02-2001
		BR 0003633 A	07-08-2001
		CN 1283539 A ,B	14-02-2001
		EP 1080847 A2	07-03-2001
		JP 2001088045 A	03-04-2001
		TW 445195 B	11-07-2001

EPC FORM P0458

For more details about this annex : see Official Journal of the European Patent Office, No. 12/82